

DATA SHEET

Hydrosonic series

Ultrasonic flow meters

For flow measurement without pressure

Hydrosonic series is a battery powered domestic water meters available in 15 mm, 20 mm, 25 mm, 32 mm, 40 mm and 50 mm line sizes. Ultrasonic water meters are extremely rugged, works using the principle of time of flight. These meters use the latest time of flight technology to achieve best accuracy.



General

HYDROSONIC SERIES has a variety of output communication options including GSM, NB-IOT, RF (Wireless M-Bus) and LORA technology. These series of water meters can calculate both forward and reverse flow, rate of flow and total flow in separate registers. State of the art electronics ensure extreme low flow sensing, large dynamic range and good stability to bubbles and particles.

HYDROSONIC SERIES has two integrally mounted transducers at an angle to the flow direction. There are no reflectors in this design minimizing the chances of failure due to failure of reflectors. The time of flight is computed by finding the time of flight that is in the direction of water flow and the time of flight in the direction opposite to water flow. The difference in the transit times is proportional to the flow rate which is measured and calibrated with actual flow. Both compensation for temperature and viscosity are built-in.

Main features

- Segmented LCD display
- Forward and reverse flow calculation
- Bluetooth BLE communication to Smart Phone and Smart Valve
- LORA, RF (Wireless M-Bus), GSM/2G/4G, NB-IOT (Factory Configurable)
- Very low flow sensing better than 0.005 m/s
- $\pm 2\%$ Accuracy over working temperature range
- Multipoint calibration
- Temperature sensing and calibration
- Special bubble detection algorithms for accurate results
- Correction for viscosity of liquid
- Battery powered. Battery life 10 years*
- Domestic water metering
- Complete profile of water usage (No water, No Flow, Low Flow, Peak Flow, Bubbles, Empty Pipe with timings on each state)
- Tamper Alert
- Freeze warning
- IP68 Ingress protection

Advantages in our design



No reflectors

Reflectors are highly polished mirrors that are used to reflect the ultrasonic waves to perpendicular sensors. However, reflectors are prone to corrosion and deposits which can hinder the reflection and stop flow sensing or result in wrong values.



Inbuilt temperature sensing

The speed of Ultrasonic waves travelling in water is dependent on temperature of water. Without temperature sensing there is no possibility of calculating time of flight. Inbuilt temperature sensing is done by the same sensors that are responsible for calculating time of flight. The design of the flow tube is experimentally qualified for temperature and viscosity sensing. Both temperature and viscosity are calculated every 1/8th second for the flow calculation algorithm.



Pressure sensing

Pressure sensors are inbuilt optionally based on customer requirements. This will measure the pressure and transmit this information to the server along with flow information.



Handling Bubbles

Undissolved gases cause bubbles to form which can hinder the detection of the ultrasonic waves. Bubbles cause attenuation of the signal as well as unwanted scattering of the signal leading to wrong flow values. In cases where there is a lot of bubbles the time of flight information can be delayed abnormally which can cause huge errors. Our algorithm is tuned to detect such abnormal values and correct them on the fly. In addition, the amplitude of the waves are monitored to make sure that the resultant waves are distorted due to bubbles and compensation is applied to regularize these waves. In cases where the internal algorithm is not able to identify the actual wave the previous rate of flow is substituted for continuous flow calculation. Since our algorithm calculates flow at 8 times a second errors are minimized and true flow calculations are performed.



Correction due to aging

The amplitude of the ultrasonic waves are monitored periodically and compared with factory calibrated values. This can change due to multiple reasons mainly aging, deposits and corrosion in the sensors. Temporary changes are caused by bubbles and impurities in water which can now be discriminated compared to long term variations. The flow calculation algorithm is tuned to discriminate these values and compensate for these values automatically. This gives long term stability and accuracy over the life of the meter.

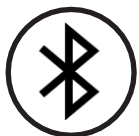

Bluetooth BLE Communication

This is standard in all models. This provides secure communication with a smart phone as well as an external smart valve. Smart App is available on both iPhone as well as Android phones.

Functional specifications

Display Parameters:

Rate of flow, Total Flow. Indicators for Forward/Reverse Flow, Pipe burst, Leak detected, Communication active, Battery Level and Alarms.

Conversion Method:

Time of flight. Bubble detection and correction algorithm. Compensation for temperature and viscosity are also inbuilt.

Stored Profiles:

The following profiles are stored in the water meter:

- a. Instantaneous Profile
- b. Billing Profile
- c. Periodic Profile
- d. Events and Alarm Profile
- e. Health Profile

Instantaneous Profile:

This gives the current Rate Flow, Forward Total Flow, Reverse Total Flow, Temperature, Pressure (optional), Monthly Total Flow and Event/Alarm Flags. Billing Profile: This gives the daily consumption readings both forward and reverse flow values for billing purposes

Periodic Profile:

This is helpful for flow supply and consumption pattern analysis. These profiles are stored at intervals defined by the user. The various parameters include

1. Rate Flow at start of profile period
2. Rate Flow at end of profile period
3. Average Rate Flow during profile period
4. Total forward flow at start
5. Total Reverse flow at start
6. Total forward flow at end
7. Total Reverse flow at end
8. Total Time of no flow during period
9. Total Time of no water during period
10. Total Time of low flow during period
11. Total Time of peak flow during period
12. Total Time of reverse flow during period
13. Events/Alarms that occurred during this period

Event/Alarm Profile:

This gives data on the time of occurrence of the alarm and the time when it became normal. An instantaneous data snapshot is attached at the time of occurrence of the alarm.

Health Profile:

This gives parameters that are necessary to assess the health of the water meter along with its communication circuits.

Digital Filter:

A programmable digital filter is used to smooth turbulent flow conditions

System Settings:

System settings are used to configure the instrument for normal operation as well as generate the different alarms in the meter. These can be changed using the communication interface

Leak Detect #1 Settings:

Leak Detect Volume#1, Leak Detect Interval#1. This leak detection algorithm accounts for a steady consumption of water during a detection window.

Leak Detect #2 Settings:

Leak Detect Volume#2, Leak Detect Interval#2. This leak detection algorithm accounts for a steady consumption of water during a detection window.

Burst Pipe Settings:

Rate flow high values for a period of time above which there is a possible burst pipe condition.

Low Flow Settings:

Rate flow low values which indicate to the user that sufficient flow is not available or consumed. This also indicates to the user that the meter may be functioning at a lower accuracy level which may reflect on the billing.

Peak Flow Settings:

Peak Rate flow values to detect if the proper line size of the water meter was chosen. Consistent peak flow will indicate that a smaller water meter was chosen for the connection.

Freeze Warning Settings:

This can send a warning if the rate of freezing is more than the set value below 5 Degrees Celsius. Both absolute alarm as well as rate of fall alarm (Temperature fall / time units below a threshold value)

Empty Pipe Alarm:

Occurs when there is no water in the pipe.

No Flow Alarm:

Occurs when there is no flow over a period of time (Hours of no flow).

Low Battery Alarm:

Battery AH calculation is done. This is more accurate compared to battery voltage detection.

Tamper Alarm:

Occurs when there a tamper is detected trying to open the enclosure.

High Temperature Warning Settings:

Can warn of excess temperature

Pulse output setting during test mode:

This setting is in Pulses/L.

Reverse reading:

Reverse readings are recorded if the flow rate falls below a threshold and continues for a set time. Reverse readings are recorded in separate registers.

Display Parameters

- a. HYDROSONIC SERIES indicates the following parameters
- b. Rate Flow (Forward / Reverse)
- c. Forward Total Flow
- d. Reverse Total Flow
- e. Forward flow in the current billing period
- f. Reverse flow in the current billing period
- g. Date/Time
- h. Communication Parameters

Leak Detect, Burst Pipe, No Flow, No Water, Tam- per, Internal Errors, Communication signal strength, Battery Level Indication Diagnostic information (For authorized service engineers only)

Diagnostics:

1. Time taken to connect to service provider / Last successful connect time
2. Time taken to connect to server / Last successful connect time
3. Data transfer time / Last successful transfer time
4. Last Communication Restart Time
5. Count of connect failures to service provider
6. Count of connect failures to server
7. Time Sync Count / Confirmation / Last when done / Sync. method
8. Signal strength alarm
9. Test Mode – Used for calibration
10. Diagnostic Mode – to view above variables
11. Number of Communication Restarts
12. Number of Processor Restarts
13. Error Counter
14. Last Processor Restart Time
15. Last error occur time
16. Water meter Commissioning Time
17. Hardware / Firmware Version
18. Reading overflow counter (1 byte)
19. Bubble detected – but within working range (with start and end time)
20. Bubble detected – cannot calculate flow (with start and end time)
21. Hit misses (start time / end time along with cur- rent temperature and flow rate)

Bluetooth BLE Communication:

This standard feature is used for diagnostics, configuration and reading of the water meter if the main communication method fails. The following features are available in the smart App.

- i. Reading Instantaneous data
- j. Reading profile data stored in the water meter
- k. Configuring the water meter
- l. Diagnostics of the meter
- m. Diagnostics of the main communication

In addition, the water meter can communicate to an external smart valve which can be commended for open / close from the meter.

Industry Standard Leak Detection for pressurized lines:

In systems where an external valve is connected and the water supply is to a user on a pressurized connection a true leak detect can be employed. The water meter can periodically close the valve on the inlet of the meter and then check if there is a pressure drop on the lines going into the house. If there is a leak it is easily identified a pressure drop over a period of time. This can help the user identify small leaks in his house. This feature works only when the water is supplied to houses on pressurized lines. For application where water is given to a sump this will not be applicable.

Linearization Method

HYDROSONIC SERIES series flow meters employ a complex three- d i m e n s i o n a l analysis to adjust for water tempera- ture and measured flow rate. The below figure shows a two-dimensional approximation for a fixed temperature. This is applied using patented meth- ods for the entire temperature range.

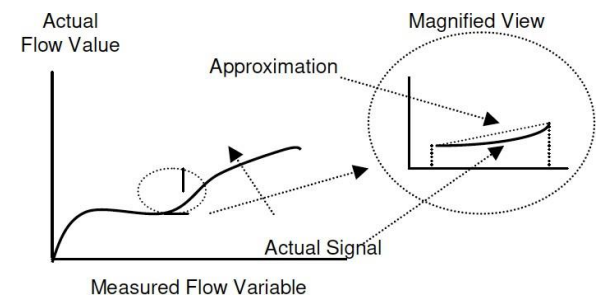

The actual process variable has a non-linear relationship to the measured process variable. A small segment is shown magnified. The total signal span is split into multiple such piecewise segments.

Communication Options:

These water meters can be factory configured in one of the following communication methods.

LoRa

RF: Wireless M-BUS with OMS2.0 NBIOT

GSM 2G/3G/4G/5G

LoRa:

This is a long-range wireless protocol working in the popular ISM frequency bands.

These meters use the LoRa WAN protocol to communicate to a gateway which then communicates to a network server.

The network server then sends this data to an application server.

LoRa devices offer 10Km line of sight communication distances.

Due to this reason LoRa is a simple star network communicating to single or multiple gateways.

Due to the nature of modulation the size of data may be small but this is ideal for water meters.

RF:

This uses the popular ISM bands for radio frequency communication to a handheld device or a collector. The format adopted is the Wireless M-Bus with OMS 2.0 which is popular across Europe. Meters can be read by walk-by, drive-by or fixed wireless methods.

NB-IoT:

This is an emerging standard promoted by the GSM service providers especially targeting the sensor m-m market. This technology gives lower battery consumption compared to GSM technology and can penetrate higher distances providing low cost communication.

GSM/GPRS/3G/4G:

This technology uses 3G/4G/2G technologies over a GSM background. These are very popular across the world. However, these technologies consume more battery power compared to any of the above mentioned technologies.

Technical data

Power supply

Powersupply	Battery Powered
Battery Life	> 10 years

Conversion Method

Signal	Ultrasonic Time of Flight (Inline measurement)
Signal Frequency	2 Mhz
Maximum Velocity	10 m/s
Minimum Velocity	0.005 m/s

Accuracy

Repeatability	+ - 0.2%
Accuracy Class	B

Interface

Display	Segmented LCD Display
Operations	Programming through BLE
External Valve Control	Over BLE
Smart Phone interface	Over BLE
Firmware Update	Over the air using BLE

Communication

	(Configurable at Factory Only)
LORA	LORAWAN
RF	Wireless M-Bus
NBIOT	MQTT protocol
GSM	MQTT protocol

Parameters

Flow Rate	m3/hr / LPH
Forward / Reverse	Indicated on Screen
Total Flow	Forward Total Flow / Reverse Total Flow
Indications	Direction, Burst Pipe, Low Battery, Signal Strength, Leak Detect, Low Pressure and Internal Errors

RTC

Real Time Clock	Builtin
Real Time Clock Sync.	Automatic during communication

Memory

Memory Type	Non-Volatile memory
Billing Profile	Last 180 days
Periodic Profile	15 minutes interval, last 90 days
Events/Alarms Profile	Last 200 events/alarms
Memory Retention	100 years

Log

Periodic Log	Rate Flow and Total Flow
Daily Log	Daily total flow
Error Log	Last 100 errors

Environmental

Operating Temperature:	0 to 55 °C
Storage Temperature	0 - 80 °C
Pressure	1.6 MPa Maximum
Ingress Protection	IP68

Dimension sizing chart

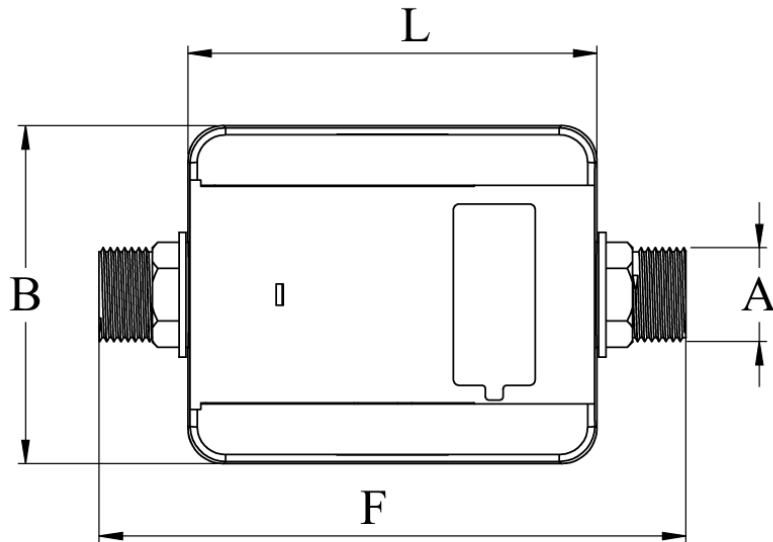

SI no	Model	Size	Length (L)	Breadth (B)	Face to Face (F)	Bore diameter (A)
1	Hydrosonic series	DN15	123	104	165	24.60
2	Hydrosonic series	DN20	123	104	190	30.80
3	Hydrosonic series	DN 25	123	104	260	39.50
4	Hydrosonic series	DN 32	123	104	260	45.20
5	Hydrosonic series	DN 40	123	104	300	57.20

Hydrosonic flow rates

- 1) Flow rates pertaining to R400
- 2) Hydrosonic meter is OIML – R49 compliant

R value 400

Line Size	Q3 (Permanent Nominal flow rate m3/hr)	Q4/Overload flow rate m3/hr	Q2 Transitional flow rate m3/hr	Q1 (Min. Flow Rate) m3/hr
15 mm	2.5	3.125	0.01	0.0062
20 mm	4	5	0.016	0.01
25 mm	10	12.5	0.04	0.025
32 mm	10	12.5	0.04	0.025
40 mm	25	31.25	0.1	0.0625

R value 800

Line Size	Q3 (Permanent Nominal flow rate m3/hr)	Q4/Overload flow rate m3/hr	Q2 Transitional flow rate m3/hr	Q1 (Min. Flow Rate) m3/hr
15 mm	2.5	3.125	0.005	0.0031
20 mm	4	5	0.008	0.005
25 mm	10	12.5	0.02	0.0125
32 mm	10	12.5	0.02	0.0125
40 mm	25	31.25	0.05	0.03125